

**VFXO401**  
**XO 2.5V, 3.3V**  
**5x7mm SMD, LVPECL / LVDS**

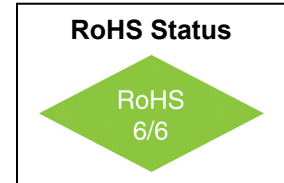

**Features**

- 15MHz to 320MHz Frequency Range
- 2.5V, 3.3V Supply Voltage
- Tight duty cycle
- <1ps jitter over 12KHz ~ 20MHz

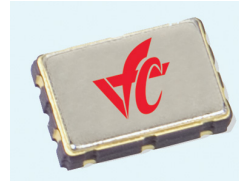

**Applications**

- Optical Networking, SONET / SDH
- 10 Gigabit Ethernet
- Broadband Access

**Electrical Specifications**

Parameter	Symbol	Condition	Min	Typ	Max	Unit	Note
Frequency Range	F	LVPECL Output Logic LVDS Output Logic	15 80		320 300	MHz	
Frequency Stability	$\Delta F/F$	Over all conditions of :- Operating Temperature; Supply Voltage; 10 Years Aging; shock & vibration			$\pm 100$ $\pm 50$ $\pm 25$ $\pm 20$	ppm	Order Code A Order Code B Order Code C Order Code D
Operating Temperature	T		0° -40°		+70° +85°	°C	Order Code B Order Code G
Output			LVPECL LVDS				Order Code L Order Code D
Supply Voltage	Vcc		3.15 2.38	3.30 2.50	3.45 2.63	V	Order Code G Order Code E
Input Current	Icc	LVPECL LVDS		58 45	88 66	mA	



**VFXO401**  
**XO 2.5V, 3.3V**  
**5x7mm SMD, LVPECL / LVDS**



**Electrical Specifications**

Parameter	Symbol	Condition	Min	Typ	Max	Unit	Note
Output Load	50 Ohm to Vcc-2V or Thevenin Equivalent Bias Required						LVPECL
	100 Ohm (1.2V offset typical)						LVDS
Duty Cycle			45 47.5	50 50	55 52.5	%	Order Code B Order Code C
Rise / Fall Time	Tr/Tf	20% to 80%		0.5	0.8	ns	
HIGH level output voltage	Voh	3.3V LVPECL 2.5V LVPECL	2.28 1.48	2.35 1.55	2.42 1.76	V	
		LVDS	-	1.43	1.60	V	
LOW level output voltage	Vol	3.3V LVPECL 2.5V LVPECL	1.49 0.69	1.60 0.80	1.68 1.10	V	
		LVDS	0.90	1.10	-	V	
Enable Function "1"	V <sub>IH</sub>		0.7V <sub>cc</sub>		-	V	
Disable Function "0"	V <sub>IL</sub>		-		0.3V <sub>cc</sub>	V	
Start up time				2	10	ms	
Jitter 12KHz~20MHz	1σ				0.7	ps	

**How to Order**

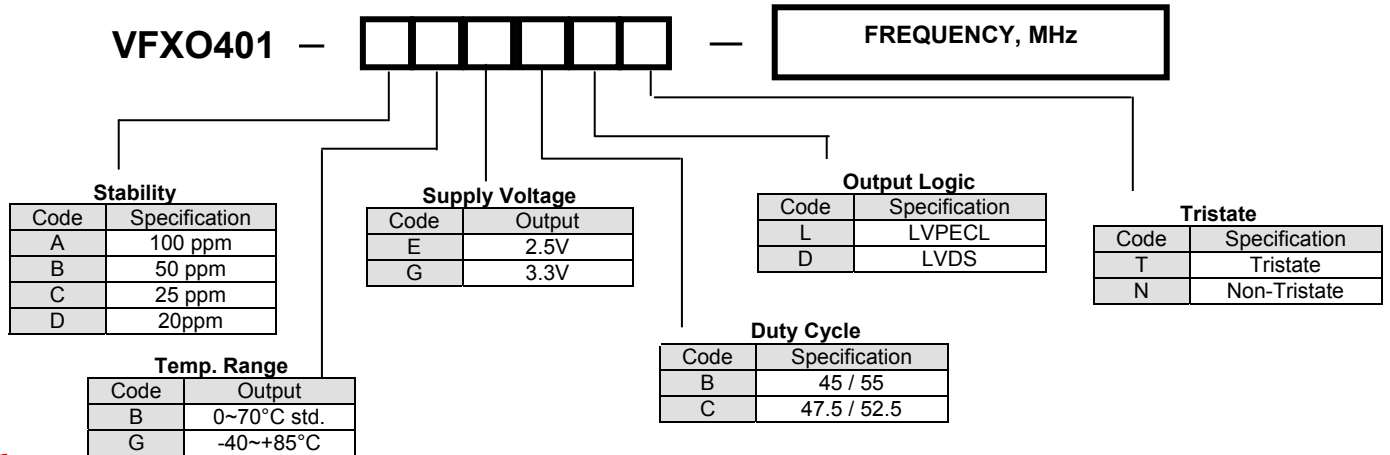

**VFXO401**  
**XO 2.5V, 3.3V**  
**5x7mm SMD, LVPECL / LVDS**



**Absolute Maximum Ratings**

Parameter	Symbol	Condition	Min	Typ	Max	Unit	Note
Supply Break Down Voltage	V <sub>cc</sub>		-0.5		4.6	V	
Storage Temperature	T <sub>s</sub>		-55		+125°	°C	
Junction Temperature	T <sub>j</sub>				+125°	°C	

**Environmental and Mechanical**

Parameter	Specification
Mechanical Shock	Per MIL-STD-202, Method 213, Condition E
Thermal Shock	Per MIL-STD-883, Method 1011, Condition A
Vibration	Per MIL-STD-883, Method 2007, Condition A
Soldering Conditions	260°C for 10s max
Hermetic Seal	Leak rate less than 5x10 <sup>-8</sup> atm.cc/s of helium

Pin #	Connection
1	N/C or Tristate
2	N/C
3	Case GND
4	Output
5	Output
6	V <sub>cc</sub>

